

CURVE DATA

Δ = 89° 25' 59"
R = 25.00'
T = 24.75'
L = 39.02'
C = 35.18'

BARAK LANE

33' Asphalt Pvm. w/ Curb & Gutter

FIELD NOTES

Being all that certain tract or parcel of land lying and being situated in the Richard Carter League, Bryan, Brazos County, Texas, and being more particularly described as follows:

BEGINNING: at an iron rod at the west corner of a 1.23 acre tract (called a 1.28 acre tract) conveyed to Creekside Professional Group of Bryan by W.H. Ritchey by deed recorded in Volume 352, Page 35 of the Deed Records of Brazos County, TEXAS, said iron rod also being in the Northeast right-of-way line of Kent Street;

THENCE: N 45° 40' 11" E - 377.37 feet to an iron rod for corner;

THENCE: S 43° 44' 00" E - 288.23 feet to an iron rod for corner, said iron rod also being in the Northwest right-of-way line of Barak Lane;

THENCE: S 46° 16' 00" W - 372.80 feet along said Barak Lane line to an iron rod for the beginning of a curve to the right;

THENCE: 39.02 feet around said curve to the right with a central angle of 89° 25' 59", a radius of 25.00 feet, and a chord of 35.18 feet to an iron rod in the Northeast right-of-way line of Kent Street;

THENCE: N 44° 39' 00" W - 284.33 feet along said Kent Street line to the PLACE OF BEGINNING and containing 2.46 acres more or less.

APPROVAL OF THE PLANNING COMMISSION

I, ROGER JACKSON, Chairman of the City Planning Commission of the City of Bryan, State of Texas, hereby certify that the attached plat was duly filed for approval with the City Planning Commission of the City of Bryan of the 22nd day of July, 1982, and same was duly approved on the 14th day of August, 1982 by said Commission.

Roger W. Jackson
Chairman, City Planning Commission
Bryan, Texas

CERTIFICATION BY THE DIRECTOR OF PLANNING

I, the Undersigned, Director of Planning of the City of Bryan hereby certify that the plat conforms to the City master plan, major street plan, land use plan, and the standards and specifications set forth in the Ordinance.

Cliff Miller
Director of Planning, Bryan, Texas

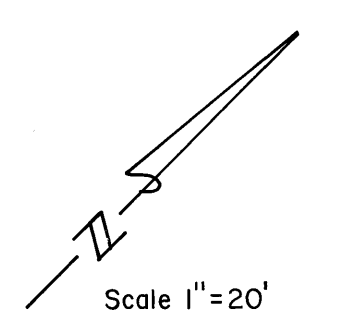

OWNER'S ACKNOWLEDGEMENTS AND DEDICATIONS:

STATE OF TEXAS
COUNTY OF BRAZOS

I, (we), W.H. Ritchey, Owner(s) and Developer(s) of the land shown on this plat, as conveyed in the Deed Records of Brazos County, Texas, Volume _____, and designated herein as the _____ Subdivisions to the City of Bryan, Texas, and whose name is subscribed hereto, hereby dedicate to the use of the public forever all streets, alleys, parks, water courses, drains, easements and public places thereon shown for the purpose and consideration therein expressed.

W.H. Ritchey
Owner

W.H. Ritchey
Leinholder

STATE OF TEXAS
COUNTY OF BRAZOS

Before me, the undersigned authority, on this day personally appeared W.H. Ritchey, known to me to be the person whose name is subscribed to the foregoing instrument, and acknowledged to me that he executed the same for the purpose and consideration therein stated.

GIVEN under my hand and seal on this 29 day of December, 1982.

Ornella Pruitt
Notary Public, Brazos County, Texas

CERTIFICATE BY THE ENGINEER

STATE OF TEXAS
COUNTY OF BRAZOS

I, Donald D. Garrett, Registered Professional Engineer, No. 22790, in the State of Texas, hereby certify that I have given proper engineering consideration to the foregoing instrument, and certify that the same is correct and true to the best of my knowledge and belief.

Donald D. Garrett
Registered Professional Engineer

CERTIFICATION OF THE SURVEYOR

STATE OF TEXAS
COUNTY OF BRAZOS

I, Donald D. Garrett, Registered Public Surveyor in the State of Texas, hereby certify that this plat is correct and was prepared from a true and correct survey properly made under my supervision.

Donald D. Garrett
Registered Public Surveyor

CERTIFICATION BY THE COUNTY CLERK:

STATE OF TEXAS
COUNTY OF BRAZOS

I, Frank Bourdieu, County Clerk in and for said County, do hereby certify that this plat together with its certificates of authentication was filed for record in my office the 4 day of January, 1983, in the Deed Records of Brazos County in Volume 358 Page 385.

Frank Bourdieu by Cheryl Thompson
County Clerk, Brazos County, Texas

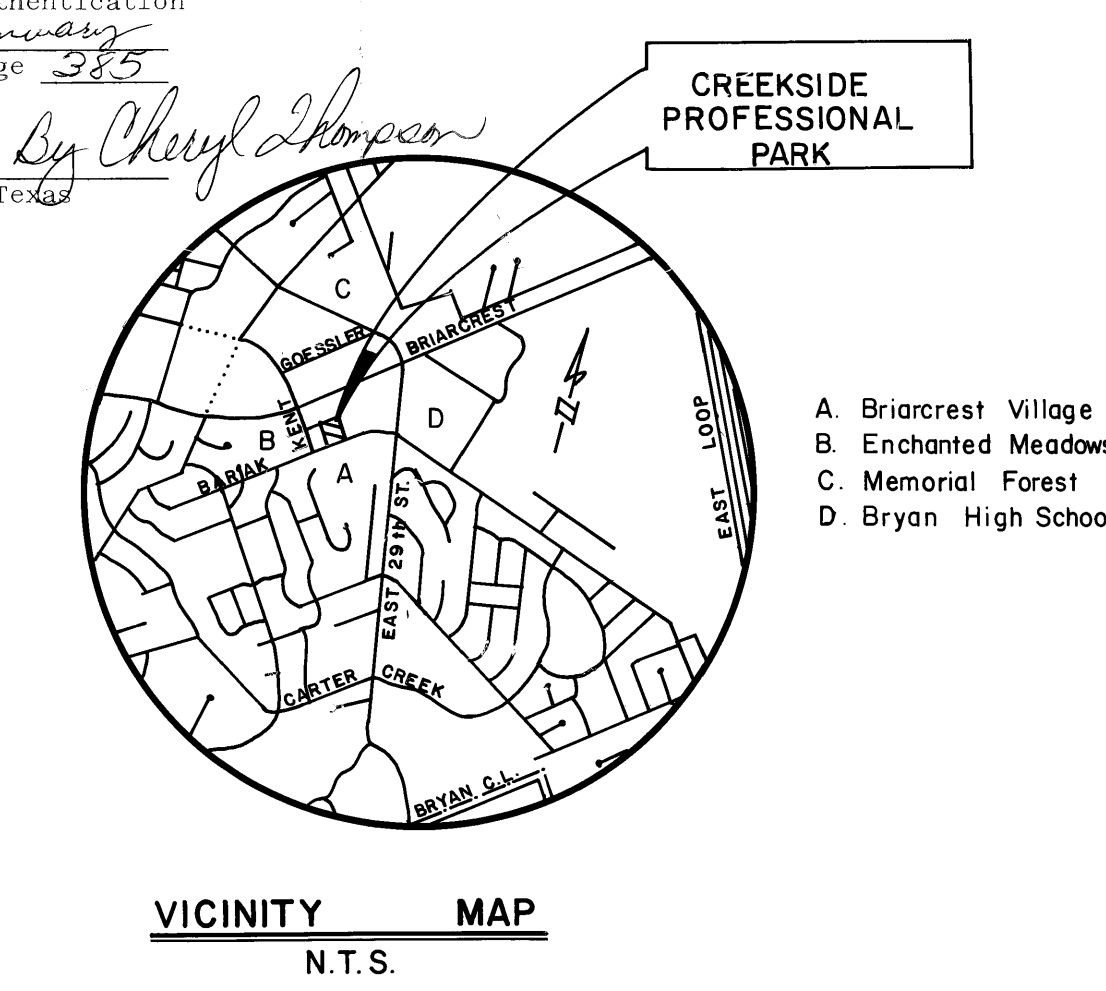

- NOTES:**
1. Sideyard Setback Line is 5'
 2. Drainage to be Contained in Natural Channel
 3. Excess Water to be Retained Parking Lot as per Drainage Report
 4. Before Bidg. Permit is Issued Check Findings of Engineering Report of Dates on Sewer Capacity Filed w/ City Engineer of the City of Bryan

LAND USE: 2 COMMERCIAL LOTS

FINAL PLAT

CREEKSIDE PROFESSIONAL PARK

2.46 ACRES
RICHARD CARTER LEAGUE
ABSTRACT NO. 8
BRYAN, BRAZOS COUNTY, TEXAS

SCALE 1" = 20' JULY, 1982

OWNER & DEVELOPER JAMES B. WILSON, ET AL 1615 Barak Lane Bryan, Texas 77801	ENGINEER & SURVEYOR GARRETT ENGINEERING 1520 Cavitt Avenue Bryan, Texas 77801
---	---